



## **SC70 Diamond Grinder Manual**



SASE Company, Inc.  
Phone 800.522.2606 or Fax 877.762.0748  
[www.SASECompany.com](http://www.SASECompany.com)



Corporate Office  
26423 79<sup>th</sup> Ave South  
Kent, WA 98032-7321  
1.800.522.2606 (P)  
1.877.762.0748 (F)  
[www.SASECompany.com](http://www.SASECompany.com)  
[sales@SASECompany.com](mailto:sales@SASECompany.com)

Congratulations on your decision to get the Power of SASE behind you! SASE is committed to excellence, excellence in the quality of products we sell and excellence in service and support after the sale. It is important to us that your business continues to succeed and grow, and we know that the right products, service and support can have a great impact on your bottom line.

SASE has made great strides in the concrete preparation and polishing industry over the years. With a 40,000 square foot distribution and service facility in Seattle, a 22,000 square foot distribution and service facility in Knoxville, and local sales and technical support representatives throughout the United States, SASE is able to provide unsurpassed service and technical support for the contractor.

At SASE we engineer and manufacture our own equipment, which allows us to be in control of the quality of the equipment we sell. SASE offers a complete line of concrete preparation and polishing equipment, our newest introduction being our new line of PDG planetary diamond grinders, which is setting a new standard for the concrete grinding and polishing industry. SASE is also the leader in diamond tooling technology.

We look forward to a long and prosperous partnership with you! Thank you again for choosing SASE. You won't regret having the Power of SASE behind your company!

Sincerely,

SASE Company, Inc.

Jim Weder

President

## SASE Company Inc. Equipment Safety Policy Statement

SASE Company, Inc. is adamant that safety is the highest priority for both our employees and customers. When considering set-up and operation of any piece of equipment supplied, manufactured, distributed, rented or serviced by SASE Company, Inc. the safety and protection of people should always be the top priority.

All customers and employees should follow all OSHA and local safety standards, requirements and regulations.

The use of the following safety equipments are both recommended and required when operating any piece of equipment supplied, manufactured, distributed, rented or serviced by SASE Company, Inc.

- OSHA approved/certified eye protection (safety glasses).
  - OSHA approved/certified hearing and ear protection.
  - OSHA approved/certified foot protection (steel toed boots).
  - OSHA approved/certified respirator or breathing device.
  - OSHA approved head protection (hard hat).
  - Proper protective work gloves.
  - Proper protective clothing limiting skin exposure.
- (The list is not meant to be all inclusive, please exercise sound judgments during operation)

The work area must always have proper ventilation to minimize the health and safety risks of propane and gasoline emissions and airborne dust.

All SASE Company Equipment is engineered, designed and provided with dust control shrouds and vacuum ports. It is strongly recommended that an approved dust containment system be connected to and used in conjunction with all SASE Company equipment during operational use. SASE Company supplies, distributes, rents and services dust control systems with HEPA filtration.

**Extreme caution must be exercised at all times when electrical power is considered. All SRT employees are prohibited from working on or hard wiring our equipments to any power source that has not been provided by SASE Company Inc. Any such work must be performed by a certified electrical technician. No SASE employee is permitted or authorized to work on, operate, or connect our equipment or equipment belonging to our customers to an electrical source that does not meet OSHA approved specifications. There are no exceptions to this policy! SASE Company Inc also strongly recommends that only certified electricians be permitted to deal with or manipulate electrical power sources within our customers' facilities or on their job-sites.**

Finally, we at SASE Company, Inc. cannot stress enough the importance of following general safety practices, the utilization of appropriate safety equipment and the application of common sense when operating equipment supplied, manufactured, distributed, rented or serviced by SASE Company, Inc. both on the job-site and in the field.

*(JLL 07/2010)*

The **SASE SC70** Hand Held Diamond Grinder provides a safe, convenient and effective way to prepare a concrete surface or remove a coating. It is ideal for both small jobs and edge work on larger jobs. The grinding portion of the **SASE SC70** is completely shrouded allowing for dust free operation.

## **SAFETY INSTRUCTIONS**

- NEVER operate this tool without proper eye, hand, respiratory and hearing protection.
- NEVER attempt to change the diamond wheel without disconnecting from power source first.
- NEVER use a diamond wheel that is larger than 7 inches.
- NEVER use a diamond wheel that is rated for less than 8000 RPM.
- Prior to use, inspect the grinder for any damage and loose hardware.
- Before operation check the wheel for proper alignment and correct direction.
- Guard against electrical shock by not grinding in water.
- Do not use the grinder near flammable liquids or gasses.
- Do not wear loose clothing.

## **SC70 OPERATING INSTRUCTIONS**

### **OPERATION**

1. Firmly hold grinder with both hands and squeeze trigger. Slowly place grinder in contact with the surface to be prepared. Move unit back and forth while lightly applying pressure.
2. For edge work along a wall, rotate the cutaway shroud up. See Illustration on next page.

### **REPLACEMENT OF DIAMOND WHEEL**

(Always remember to disconnect grinder from power source before any work is done.)

1. Depress and hold the spindle lock to keep the wheel from turning.
2. Using a 1-inch wrench remove the nut, retaining flange and diamond wheel.
3. Install the new diamond wheel.
4. Assemble in reverse order.

## **LIMITED WARRANTY**

SASE Company, Inc. makes every effort to insure that its products meet high quality and durability standards and warrant to the original purchaser of our products that each might be free from defects in materials and workmanship as follows:

6 month limited warranty on all SASE Company, Inc. products unless specified otherwise. Warranty does not apply to wear parts or defects due directly or indirectly to misuse, abuse, negligence or accidents, repairs or alterations outside our facilities or to lack of maintenance. SASE Company, Inc. shall in no event be liable for death, injuries to persons or property or for incidental, contingent, or consequential damages arising from the use of our product.

To take advantage of this warranty the product or part must be returned for examination, postage prepaid, to an authorized repair center designated by our Seattle office. Proof of purchase and an explanation of the complaint must accompany the merchandise. If our inspections discloses a defect, SASE Company, Inc. we will repair or replace the product.

**SC 70 Bill of Materials**

<b>Item No.</b>	<b>Part No.</b>	<b>Description</b>	<b>Quantity</b>
1	NB.13.117	1/4-20 X 1/2 Flat Head Socket Screw Unplated	4
			1
			1
4	SC70.900001	SO# Vacuum Shroud	1
5	SC70.900002	Loop Handle	1
6	SC70.900200	Bottom Flange	1
7	SC70.900500	Tube, 4" with 45 Degree Angle SC70*	1
8	SC70.900702	Metabo Angle Grinder W23-180 8500 RPM 7"	1
9	SC70.900802	Hex Jam Nut	1
10	SC70.900803	Hex Screw for Loop Handle	3
11	SC70.900804	Lock Washer for Loop Handle	3
12	SC70.900900	Adapter Ring for Metabo	1
13	SC70.900901	1/4-20 x 1/2 Socket Set Screw Unplated	3
14	SC70.900918	7" Convertible Shroud	1
			1
16	SC70.900917	Beneath Wheel Spacer	1
			1

# SC70

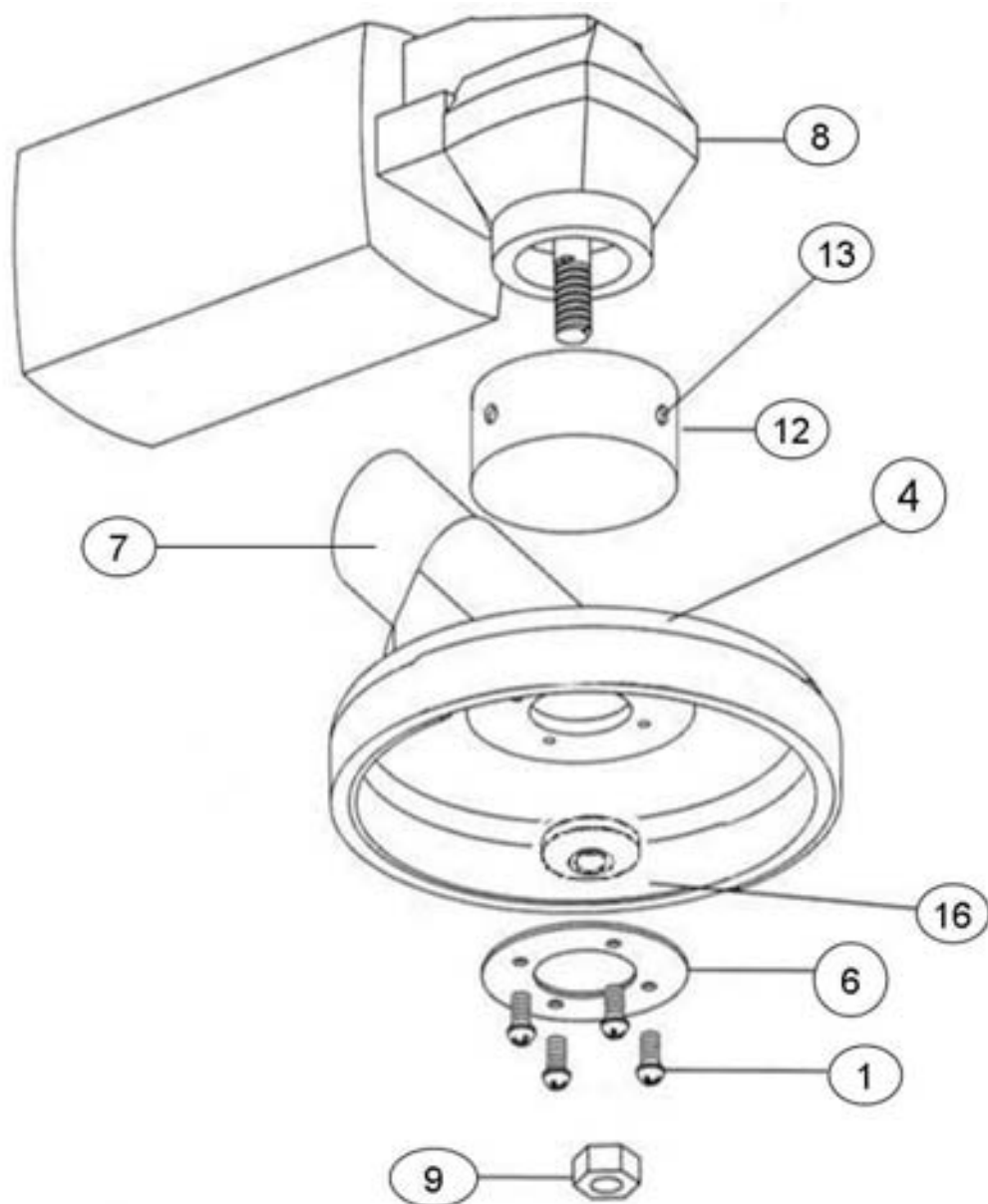

<b>SC 70 Assembly</b>			
<b>Item No.</b>	<b>Part No.</b>	<b>Description</b>	<b>Quantity</b>
1	NB.13.117	1/4-20 X 1/2 Flat Head Socket Screw Unplated	4
4	SC70.900001	SO# Vacuum Shroud	1
6	SC70.900200	Bottom Flange	1
7	SC70.900500	Tube, 4" with 45 Degree Angle SC70*	1
8	SC70.900702	Metabo Angle Grinder W23-180 8500 RPM 7"	1
9	SC70.900802	Hex Jam Nut	1
12	SC70.900900	Adapter Ring for Metabo	1
13	SC70.900901	1/4-20 x 1/2 Socket Set Screw Unplated	3
16	SC70.900917	Beneath Wheel Spacer	1

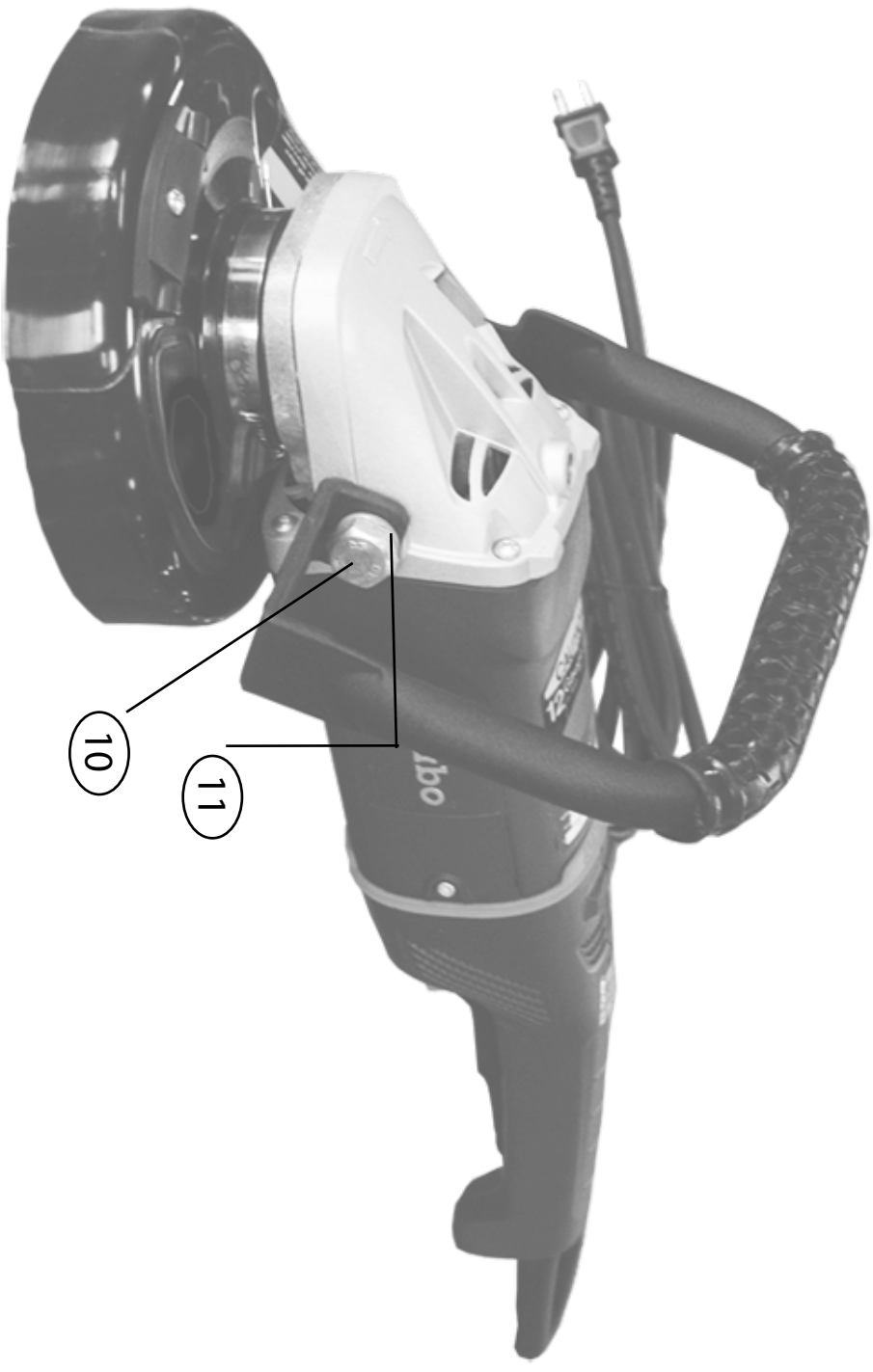

**SC 70 Side View**

<b>Item No.</b>	<b>Part No.</b>	<b>Description</b>	<b>Quantity</b>
10	SC70.900803	Hex Screw for Loop Handle	3
11	SC70.900804	Lock Washer for Loop Handle	3



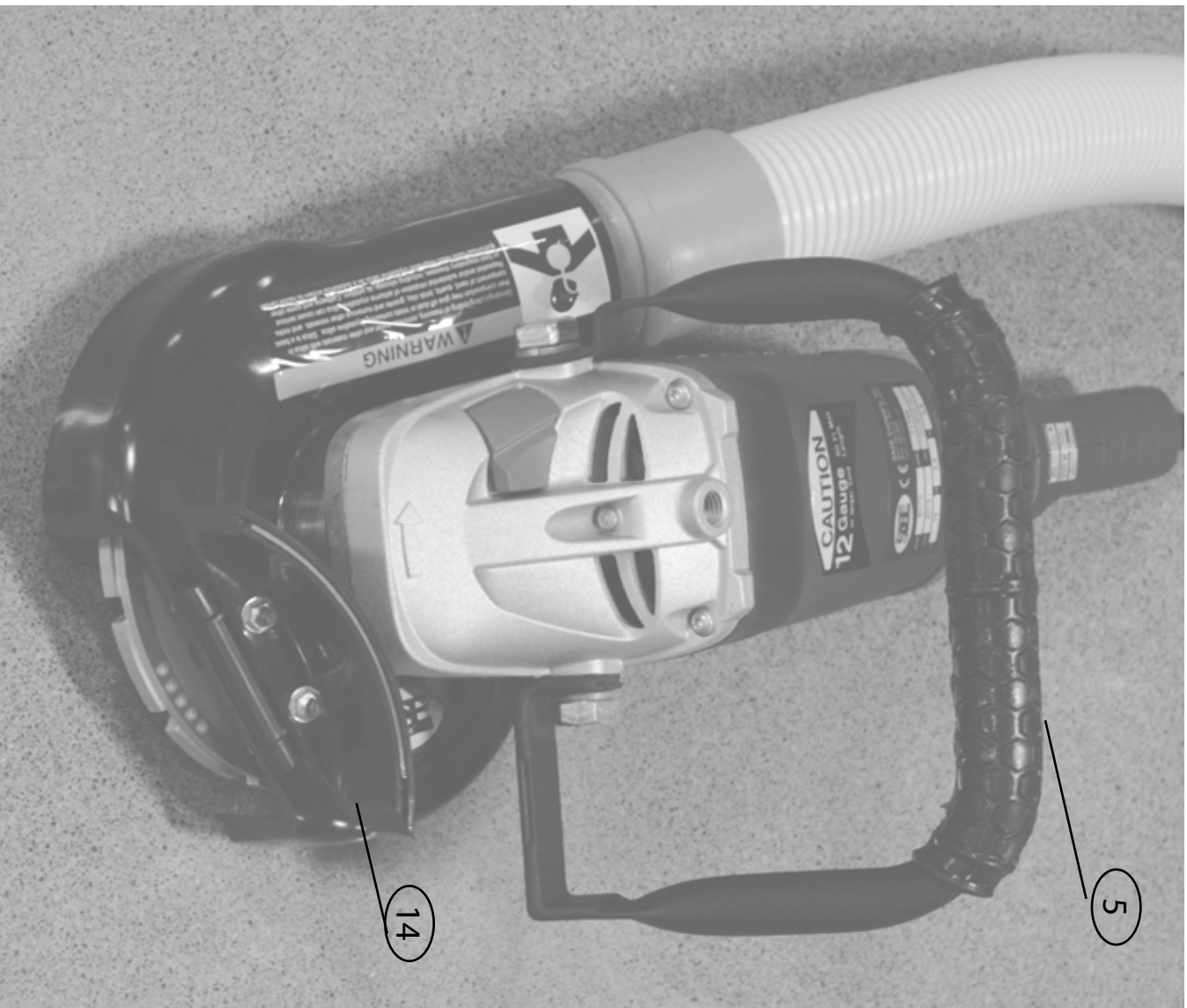

**SC 70 Top View**

Item No.	Part No.	Description	Quantity
5	SC70.900002	Loop Handle	1
14	SC70.900918	7" Convertible Shroud	1