



## Edge Pro 180 Manual



SASE Company, Inc.  
Phone 800.522.2606 or Fax 877.762.0748  
[www.SASECompany.com](http://www.SASECompany.com)





Corporate Office  
26423 79<sup>th</sup> Ave South  
Kent, WA 98032-7321  
1.800.522.2606 (P)  
1.877.762.0748 (F)  
[www.SASECompany.com](http://www.SASECompany.com)  
[sales@SASECompany.com](mailto:sales@SASECompany.com)

Congratulations on your decision to get the Power of SASE behind you! SASE is committed to excellence, excellence in the quality of products we sell and excellence in service and support after the sale. It is important to us that your business continues to succeed and grow, and we know that the right products, service and support can have a great impact on your bottom line.

SASE has made great strides in the concrete preparation and polishing industry over the years. With a 40,000 square foot distribution and service facility in Seattle, a 22,000 square foot distribution and service facility in Knoxville, and local sales and technical support representatives throughout the United States, SASE is able to provide unsurpassed service and technical support for the contractor.

At SASE we engineer and manufacture our own equipment, which allows us to be in control of the quality of the equipment we sell. SASE offers a complete line of concrete preparation and polishing equipment, our newest introduction being our new line of PDG planetary diamond grinders, which is setting a new standard for the concrete grinding and polishing industry. SASE is also the leader in diamond tooling technology.

We look forward to a long and prosperous partnership with you! Thank you again for choosing SASE. You won't regret having the Power of SASE behind your company!

Sincerely,

SASE Company, Inc.

A handwritten signature in black ink, appearing to read "J. Weder", written in a cursive style.

Jim Weder

President



## **SASE Company Inc. Equipment Safety Policy Statement**

SASE Company, Inc. is adamant that safety is one of the highest priorities for both our employees and customers. When considering set-up and operation of any piece of equipment supplied, manufactured, distributed, rented or serviced by SASE Company, Inc., the safety and protection of people should always be a top priority.

All customers and employees should follow all OSHA and local safety standards, requirements and regulations.

The use of the following safety equipments are both recommended and required when operating any piece of equipment supplied, manufactured, distributed, rented or serviced by SASE Company, Inc.

- OSHA approved/certified eye protection (safety glasses).
- OSHA approved/certified hearing and ear protection.
- OSHA approved/certified foot protection (steel toed boots).
- OSHA approved/certified respirator or breathing device.
- OSHA approved head protection (hard hat).
- Proper protective work gloves.
- Proper protective clothing limiting skin exposure.

(The list is not meant to be all inclusive. Please exercise sound judgments during operation.)

The work area must always have proper ventilation to minimize the health and safety risks of propane and gasoline emissions and airborne dust.

All SASE Company Equipment is engineered, designed and provided with dust control shrouds and vacuum ports. It is strongly recommended that an approved dust containment system be connected to and used in conjunction with all SASE Company equipment during operational use. SASE Company supplies, distributes, rents and services dust control systems with HEPA filtration.

**Extreme caution must be exercised at all times when electrical power is considered. All SASE employees are prohibited from working on or hard wiring our equipments to any power source that has not been provided by SASE Company Inc. Any such work must be performed by a certified electrical technician. No SASE employee is permitted or authorized to work on, operate, or connect our equipment or equipment belonging to our customers to an electrical source that does not meet OSHA approved specifications. There are no exceptions to this policy! SASE Company, Inc. also strongly recommends that only certified electricians be permitted to deal with or manipulate electrical power sources within our customers' facilities or on their job-sites.**

Finally, we at SASE Company, Inc. cannot stress enough the importance of following general safety practices, the utilization of appropriate safety equipment and the application of common sense when operating equipment supplied, manufactured, distributed, rented or serviced by SASE Company, Inc. both on the job-site and in the field.

*(JL 07/2010)*



**EDGE PRO 180 BILL OF MATERIALS DG.EDGE180.02**

AIW.16X4CRD	CORD, POWER 16/4	2 FT	DG.1411	SCREW, HEX BUTTON HEAD M10 X 30 BLACK	2 EA
795.00.07	1/2-IN BLACK CORD GRIP SLN13	2 EA	DG.1412	STANCION, #8-32 MALE - FEMALE 1-3/8" TALL	6 EA
DG.1313	COUPLER, FLEX LOVEJOY	1 EA	DG.1413	NUT, #8 -32 ZINC NYLOC	6 EA
DG.1316	WHEEL, FOUR ARM 3"	1 EA	DG.1416	SO# NUT, HEX JAM 1/4-20 ZINC	4 EA
DG.1317	PIN, CLEV W/CTTRS 5/16"	1 EA	DG.1417	BREAKER, CIRCUIT 20A	1 EA
DG.1318	WHEEL, REAR 4" X 2"	2 EA	DG.1418	MOTOR, 1HP EDGER	1 EA
DG.1322	RING, SNAP M19	4 EA	DG.1419	SCREW, HEX SOCKET3/8-16 X 1 BLACK	4 EA
DG.1323	BOLT, SWING M8 X 100	1 EA	DG.1420	PULLEY, M8 20MM WIDE 38 TOOTH	1 EA
DG.1325	NUT, 5/16" ACORN	1 EA	DG.1421	BUSHING, M19 SHAFT	1 EA
DG.1327	WASHER, LOCK M8	2 EA	DG.1422	BELT, EDGER 800-8MGT-20 TOOTHED	1 EA
DG.1329	WASHER, FLAT 3/4"	4 EA	DG.1423	BOLT, U	2 EA
DG.1332	NUT, HEX M8	2 EA	DG.1424	WASHER, 3/8 SLAT WASHER ZINC WIDE 0.375	5 EA
DG.1337	SCREW, SOCKET HEAD M10 X 35	6 EA	DG.1426	FITTING, GREASE STRIGHT M6 EDGER	1 EA
DG.1341	KNOB, PLASTIC M8	1 EA	DG.1427	SO# BODY, HEAD EDGER	1 EA
DG.1349	HANDLE, ASSEMBLY	1 EA	DG.1430	SWITCH, ON/OFF ROCKER SPDT EDGER SERIAL# 1120 AND ABOVE	1 EA
DG.1353	CARRIAGE, SHG AND EDGER	1 EA	DG.1431	SO# PLATE, MOTOR MOUNT EDGER	1 EA
DG.1354	YOKE, ADJUSTER SHG EDGER	1 EA	DG.1432	SO# PLATE, ACESS COVER EDGER	1 EA
DG.1358	ENCLOSURE, CONTROL EDGER	1 EA	DG.1433	SWITCH, LEFT/RIGHT ROCKER SPDT EDGER	1 EA
DG.1361	GRIP, LOWER HANDLE SHG EDGER	1 EA	DG.1434	SO# POTENTIOMETER, EDGER	1 EA
DG.1362	GRIP, MAIN HANDLE SHG EDGER	1 EA	DG.1437	NUT, "T" 1/2" SLOT 3/8-16 THREAD	4 EA
DG.1366	COVER, ENCLOSURE CONTROL	1 EA	DG.1442	COVER, BEARING CAVITY EDGER	1 EA
DG.1368	AXLE, WHEEL SHG AND EDGER	1 EA	DG.1443	SPIDER, DISC DRIVE EDGER	1 EA
DG.1374	PLUG, BLACK DOME 3/4" SHG	2 EA	DG.1444	CONTROLLER, EDGER MOTOR KBVF-26D GFCI	1 EA
DG.1375	PLUG, BLACK DOME 2" SHG	1 EA	DG.1445	SHAFT, MAIN EDGER	1 EA
DG.1385	CABLE, 22 AWG 6 STRAND	3 FT	DG.1446	DISC, DRIVE EDGER (NO VALCRO)	1 EA
DG.1387	CORD, POWER WITH PLUG	1 EA	DG.1447	CARRIER, ROTOR BEARING EDGER	1 EA
DG.1389	SCREW, SOCKET HEAD SHOULDER M10 X 10	4 EA	DG.1448	SHROUD, DUST REAR EDGER	1 EA
DG.1395	WASHER, FLAT 5/16 ZINC WIDE	4 EA	DG.1449	SHROUD, DUST FILLER EDGER	1 EA
DG.1398	BEARING, TAPERED ROLLER TIMKEN 30303	2 EA	DG.1450	SHROUD, DUST FORWARD EDGER	1 EA
DG.1399	SEAL, LIP 50 X 30 X 8	1 EA	DG.1451	PLATE, POT EDGER	1 EA
DG.1400	PIN, SPIRAL M3 X 10	1 EA	DG.1453	WEIGHT, EDGER	2 EA
DG.1401	WASHER, MACHINED	1 EA	DG.1454	NUT, 7/16-20 LEFT HAND THREAD JAM	1 EA
DG.1402	SCREW, FLAT HEAD SOCKET M6 X 20	1 EA	DG.1456	PIN, DOWEL 5/32 X 3/8 EDGER	3 EA
DG.1403	SCREW, HEX SOCKET FLANGE BUTTON HEAD #8 -32 X 3/8"	25 EA	DG.1462	KEY, TAPERLOCK	1 EA
DG.1404	SHEAVE, MODIFIED W488M22SDS*	1 EA	DG.1463	SPACER, TAPERLOCK	1 EA
DG.1405	SCREW, HEX HEAD 1/4-20 X 1-1/2" ZINC	3 EA	DG.1488	VELCRO, HOOK 6" DISC EDGER	1 EA
DG.1406	WASHER, FLAT 1" X 2-1/2" X .16 ZINC	1 EA	DG.1489	FITTING, STRAIN RELIEF 90 DEGREE	1 EA
DG.1407	NUT, HEX JAM 1-1/2	1 EA	DG.1490	DECAL KIT	1 EA
DG.1408	SCREW, FLAT HEAD SOCKET M6 X 12 YELLOW ZINC	8 EA	HOL.500-19015	BUSHING, SOFT DRIVING PLATE FOR POLISHING	2 EA
DG.1409	SCREW, HEX SOCKET M8 X 16 YELLOW ZINC	2 EA	NB.20.144	NUT, NYLON 1/2 INCH	2 EA
DG.1410	WASHER, LOCK INTERNAL TOOTH M10 BLACK	2 EA	DG.1500	WIRE HARNESS KIT	1 EA
DG.1501	NUT, HEX 1/4-20 ZINC	4 EA			

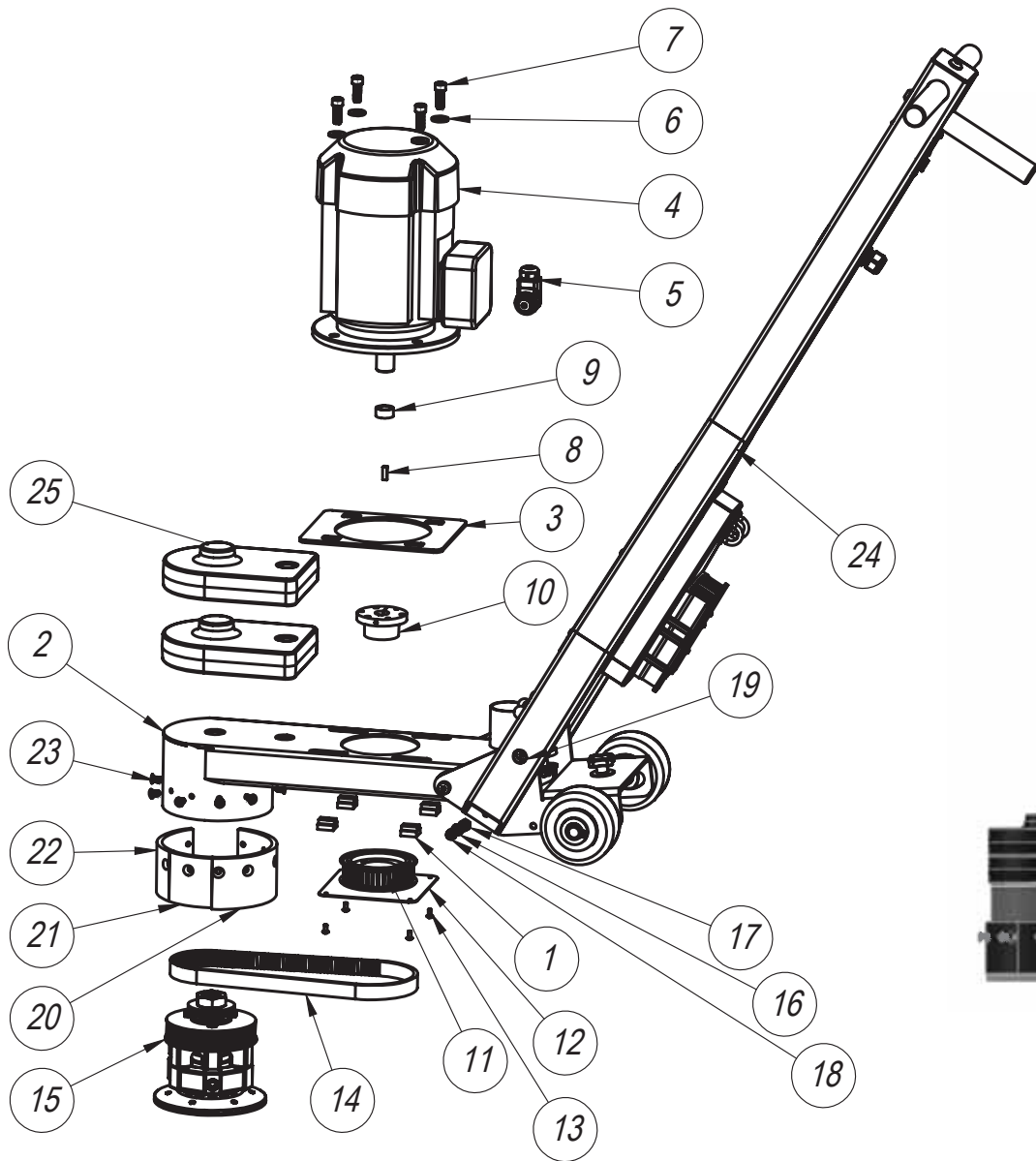

**EDGE PRO 180**  
**MOTOR & FINAL**  
**ASSEMBLY**

SCALE: 1:10 | WEIGHT: 47.99 | SHEET 1 OF 1



MOTOR ASSEMBLY			
Item No.	Part No.	Description	Quantity
1	DG.1437	NUT, "T" 1/2" SLOT 3/8-16 THREAD	4
2	SEE PAGE	CARRIAGE ASSEMBLY	1
3	DG.1431	SO# PLATE, MOTOR MOUNT EDGER	1
4	DG.1418	MOTOR, 1HP EDGER	1
5	DG.1489	FITTING, STRAIN RELIEF 90 DEGREE	1
6	DG.1424	WASHER, 3/8 SLAT WASHER ZINC WIDE 0.375	4
7	DG.1419	SCREW, HEX SOCKET 3/8-16 X 1 BLACK	4
8	DG.1462	KEY, TAPERLOCK	1
9	DG.1463	SPACER, TAPERLOCK	1
10	DG.1421	BUSHING, 19MM SHAFT	1
11	DG.1420	PULLEY, M8 20MM WIDE 38 TOOTH	1
12	DG.1432	SO# PLATE, ACCESS COVER EDGER	1
13	DG.1403	SCREW, HEX SOCKET FLANGE BUTTON HEAD #8 -32 X 3/8"	4
14	DG.1422	BELT, EDGER 800-8MGT-20 TOOTHED	1
15	SEE PAGE	DRIVEN HEAD ASSEMBLY	1
FINAL ASSEMBLY			
16	DG.1327	WASHER, LOCK M8	2
17	DG.1332	NUT, HEX M8	2
18	DG.1409	SCREW, HEX SOCKET M8 X 16 YELLOW ZINC	2
19	DG.1374	PLUG, BLACK DOME 3/4"	2
20	DG.1448	SHROUD, DUST REAR EDGER	1
21	DG.1449	SHROUD, DUST FILLER EDGER	1
22	DG.1450	SHROUD, DUST FORWARD EDGER	1
23	DG.1408	SCREW, FLAT HEAD SOCKET M6 X 12 YELLOW ZINC	8
24	SEE PAGE	HANDLE ASSEMBLY	1
25	DG.1453	WEIGHT, EDGER	2

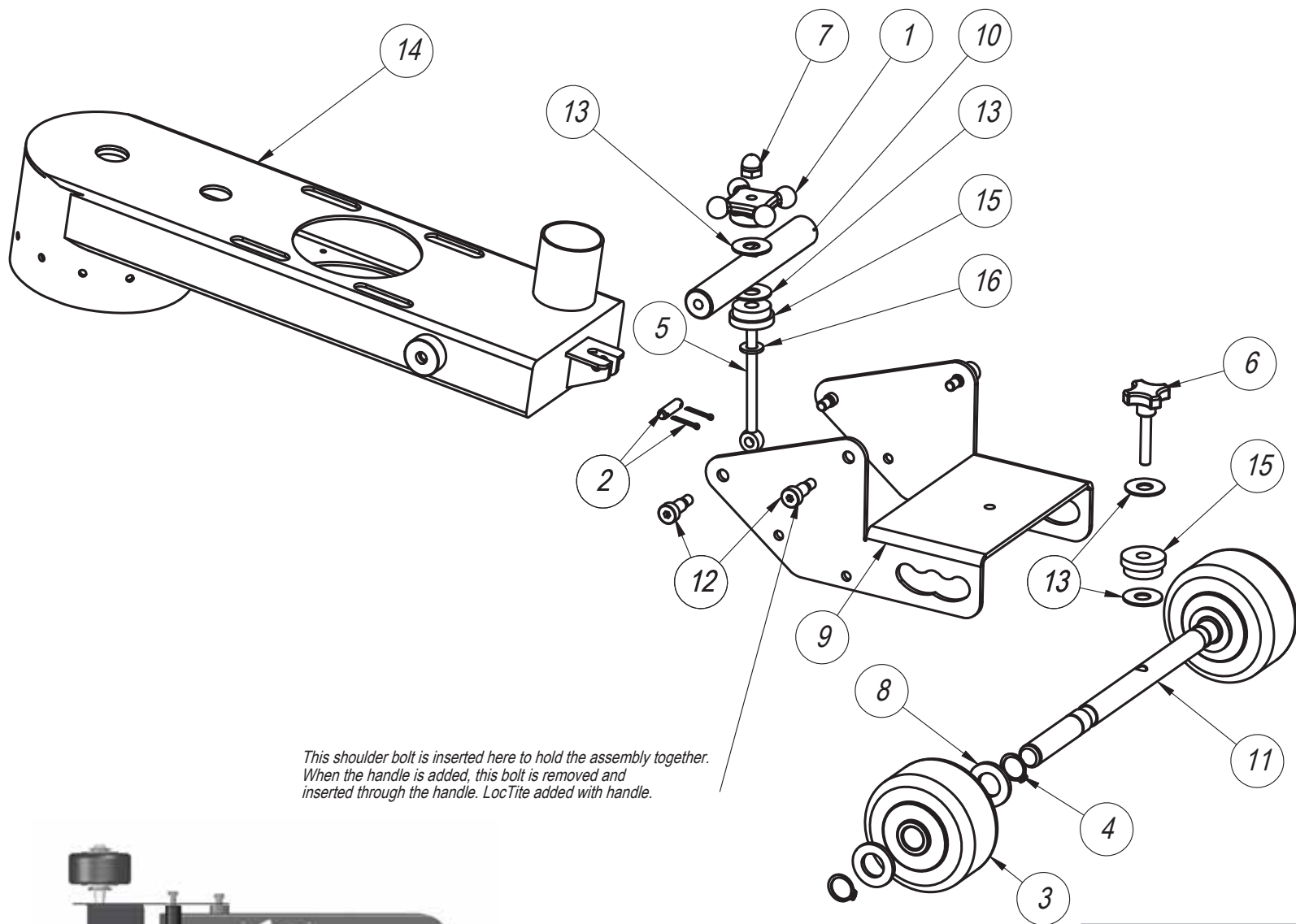

*This shoulder bolt is inserted here to hold the assembly together.  
When the handle is added, this bolt is removed and  
inserted through the handle. Loctite added with handle.*

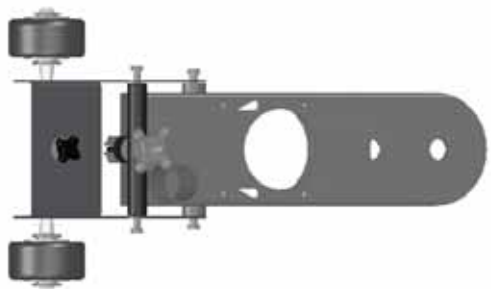

<b>EDGE PRO 180</b>		
<b>CARRIAGE ASSEMBLY</b>		
SCALE: 1:5	WEIGHT: 9.29	SHEET 1 OF 1

## Carriage Assembly

Item No.	Part No.	Description	Qty
1	DG.1316	WHEEL, FOUR ARM 3"	1
2	DG.1317	PIN, CLEV W/CTTRS 5/16"	1
3	DG.1318	WHEEL, REAR 4" X 2"	2
4	DG.1322	RING, SNAP M19	4
5	DG.1323	BOLT, SWING M8 X 100	1
6	DG.1341	KNOB, PLASTIC M8	1
7	DG.1325	NUT, 5/16" ACORN	1
8	DG.1329	WASHER, FLAT 3/4"	4
9	DG.1353	CARRIAGE, SHG AND EDGER	1
10	DG.1354	YOKE, ADJUSTER SHG EDGER	1
11	DG.1368	AXLE, WHEEL SHG AND EDGER	1
12*	DG.1389	SCREW, SOCKET HEAD SHOULDER M10 X 10	4
13	DG.1395	WASHER, FLAT 5/16 ZINC WIDE	4
14	DG.1427	SO# BODY, HEAD EDGER	1
15	HOL.500-19015	BUSHING, SOFT DRIVING PLATE FOR POLISHING	2
16	DG.1424	WASHER, 3/8 SLAT WASHER ZINC WIDE 0.375	1

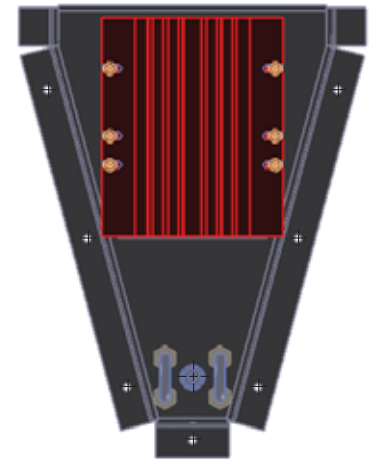
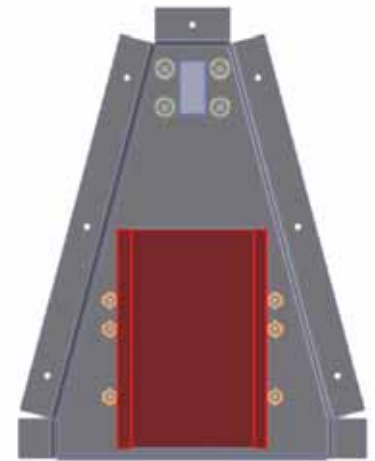
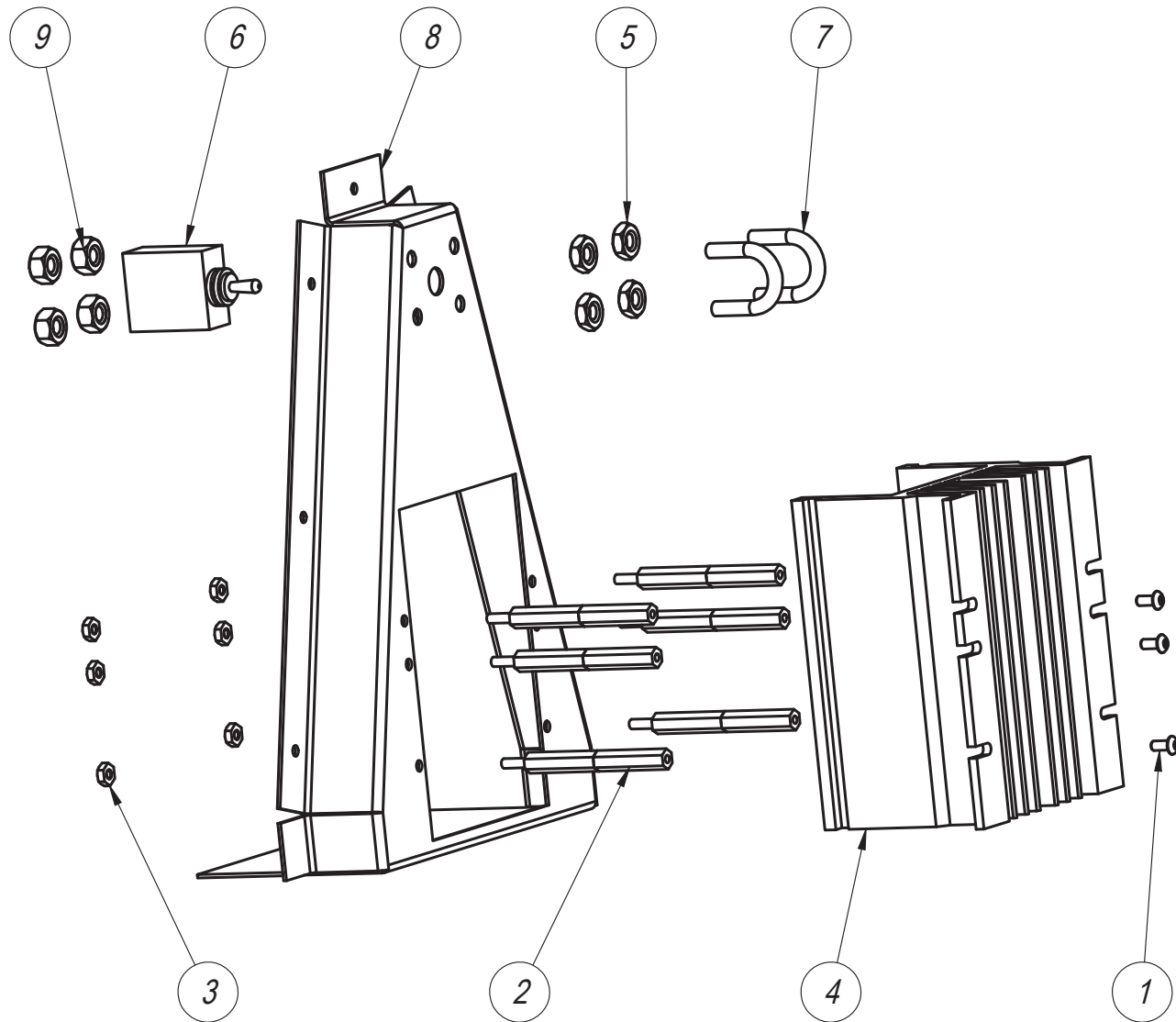

**EDGE PRO 180**

**CONTROLLER  
HOUSING**

SCALE: 1:5 | WEIGHT: 1.47 | SHEET 1 OF 1

Controller Housing			
Item No.	Part No.	Description	Qty
1	DG.1403	SCREW, HEX SOCKET FLANGE BUTTON HEAD #8 -32 X 3/8"	6
2	DG.1412	STANCION, #8-32 MALE - FEMALE 1-3/8" TALL	6
3	DG.1413	NUT, #8 -32 ZINC NYLOC	6
4	DG.1444	CONTROLLER, EDGER MOTOR KBVF-26D GFCI	1
5	DG.1416	NUT, HEX JAM 1/4-20 ZINC	4
6	DG.1417	BREAKER, CIRCUIT 20A	1
7	DG.1423	BOLT, U	2
8	DG.1358	ENCLOSURE, CONTROL	1
9	DG.1501	NUT, HEX 1/4-20 ZINC	4

Limited older versions used a NON-GFCI controller(DG.1414), with a different enclosure(DG.1429)

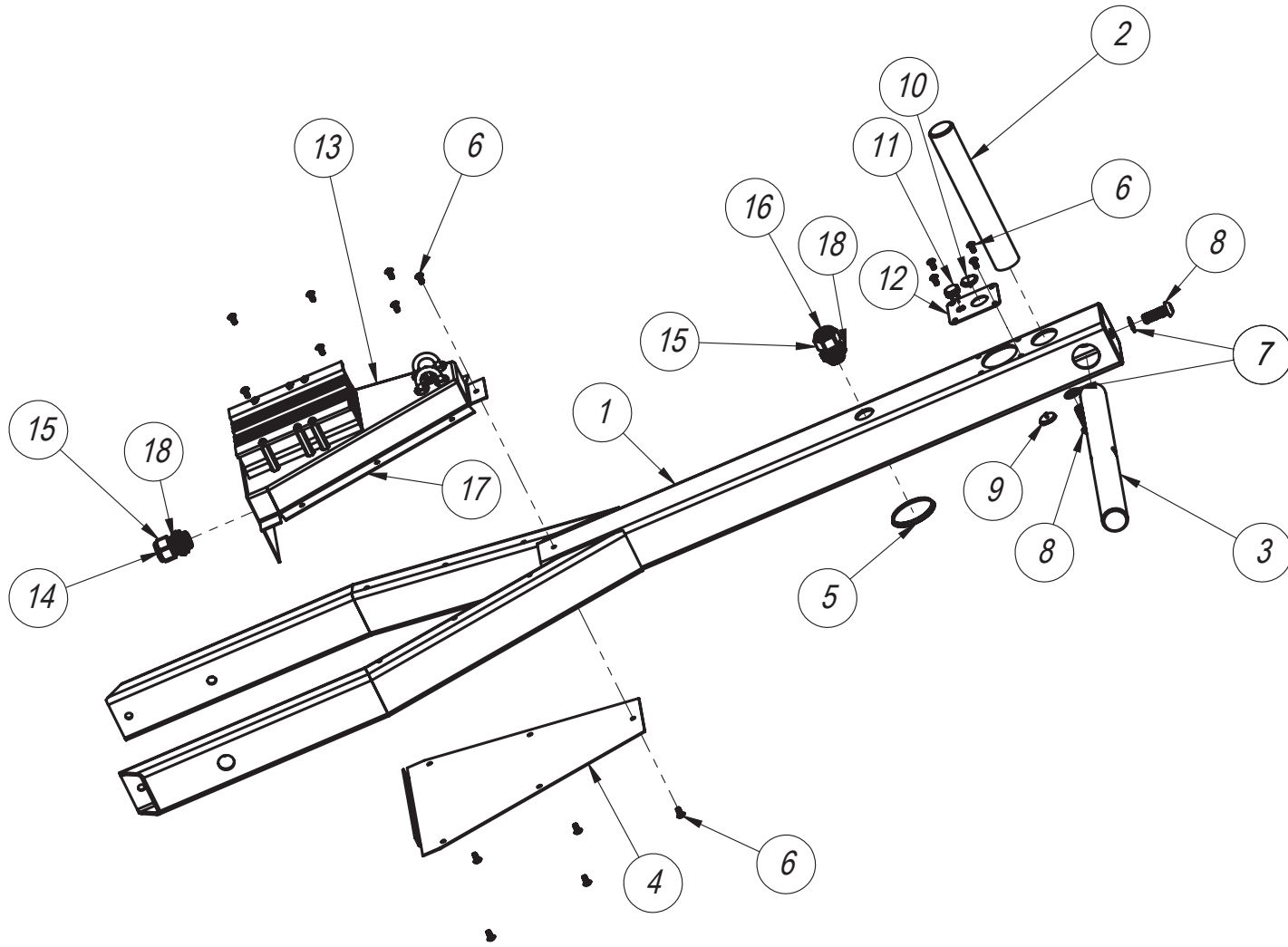

**EDGE PRO 180**

**HANDLE ASSEMBLY**

SCALE: 1:8 | WEIGHT: 12.53 | SHEET 1 OF 1

5

4

3

2

1

Handle Assembly			
Item No.	Part No.	Description	Qty
1	DG.1349	HANDLE, ASSEMBLY	1
2	DG.1361	GRIP, LOWER HANDLE SHG EDGER	1
3	DG.1362	GRIP, MAIN HANDLE SHG EDGER	1
4	DG.1366	COVER, ENCLOSURE CONTROL	1
5	DG.1375	PLUG, BLACK DOME 2"	1
6	DG.1403	SCREW, HEX SOCKET FLANGE BUTTON HEAD #8 -32 X 3/8"	16
7	DG.1410	WASHER, LOCK INTERNAL TOOTH M10 BLACK	2
8	DG.1411	SCREW, HEX BUTTON HEAD M10 X 30 BLACK	2
9	DG.1430	SWITCH, ON/OFF ROCKER SPDT EDGER	1
10	DG.1433	SWITCH, LEFT/RIGHT ROCKER SPDT EDGER	1
11	DG.1434	SO# POTENTIOMETER, EDGER	1
12	DG.1451	PLATE, POT EDGER	1
13	SEE PAGE	CONTROLLER, HOUSING	1
14	DG.1385	CABLE, 22 AWG 6 STRAND	3 FT
15	795.00.07	1/2-IN BLACK CORD GRIP SLN13	1
16	DG.1387	CORD, POWER WITH PLUG	1
17	DG.1500	HARNESS, WIRING EDGER	1
18	NB.20.144	NUT, 1/2" NYLON CONDUIT LOCK	1

Use enough silicone to seal #4 and #13 where they come in contact with #1.

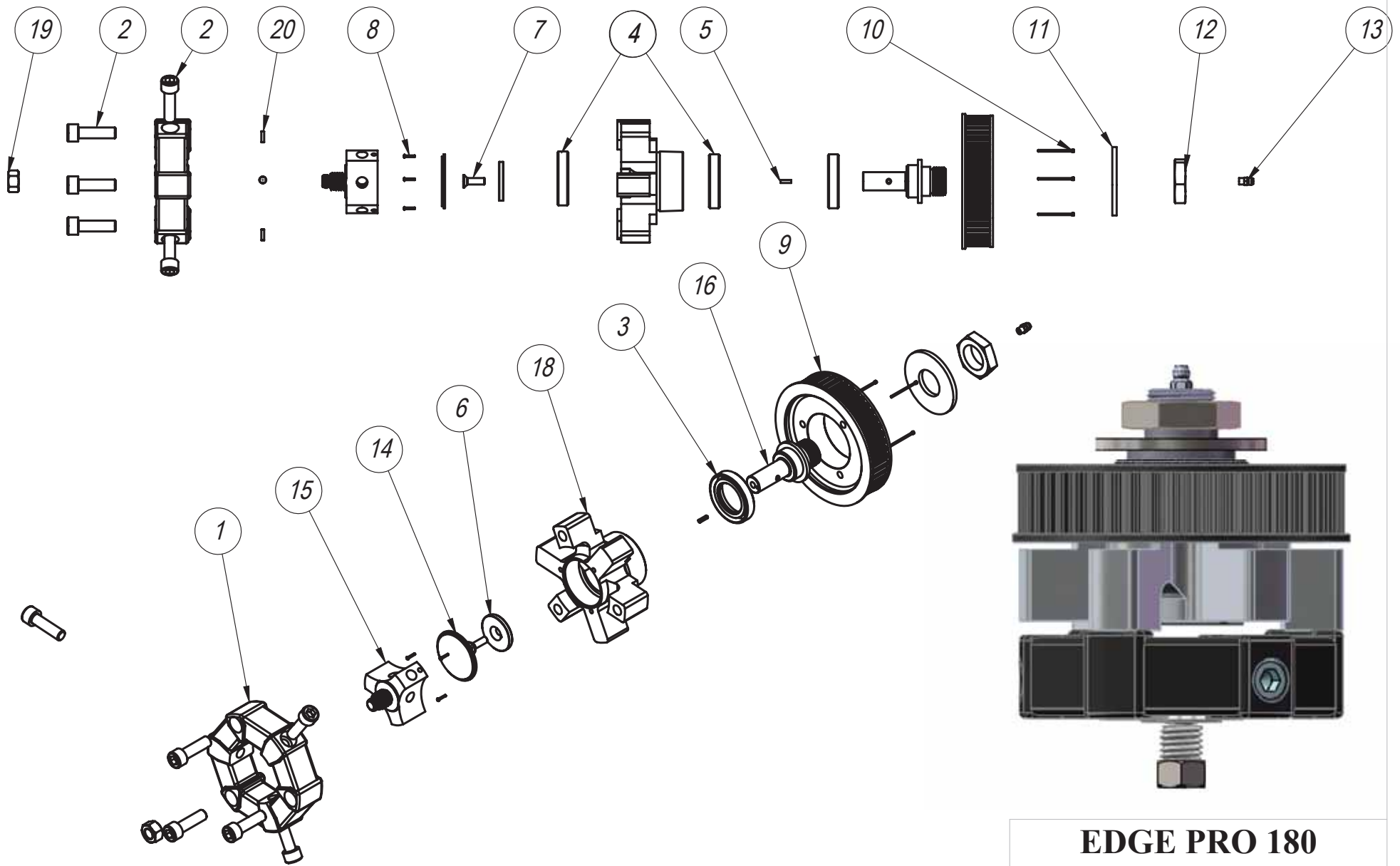

**EDGE PRO 180**

**DRIVEN HEAD**

SCALE: 1:20 WEIGHT: SHEET 1 OF 1



Driven Head			
Item No.	Part No.	Description	Qty
1	DG.1313	COUPLER, FLEX LOVEJOY	1
2	DG.1337	SCREW, SOCKET HEAD M10 X 35	6
3	DG.1399	SEAL, LIP 50 X 30 X 8	1
4	DG.1398	BEARING, TAPERED ROLLER TIMKEN 30303	2
5	DG.1400	PIN, SPIRAL M3 X 10	1
6	DG.1401	WASHER, MACHINED	1
7	DG.1402	SCREW, FLAT HEAD SOCKET M6 X 20	1
8	DG.1403	SCREW, HEX SOCKET FLANGE BUTTON HEAD #8 -32 X 3/8"	3
9	DG.1404	SHEAVE, MODIFIED W488M22SDS*	1
10	DG.1405	SCREW, HEX HEAD 1/4-20 X 1-1/2" ZINC	3
11	DG.1406	WASHER, FLAT 1" X 2-1/2" X .16 ZINC	1
12	DG.1407	NUT, HEX JAM 1-1/2	1
13	DG.1426	FITTING, GREASE STRIGHT M6 EDGER	1
14	DG.1442	COVER, BEARING CAVITY EDGER	1
15	DG.1443	SPIDER, DISC DRIVE EDGER	1
16	DG.1445	SHAFT, MAIN EDGER	1
17	DG.1492	DISC, DRIVE EDGER WITH VELCRO PLATE (Not displayed)	1
18	DG.1447	CARRIER, ROTOR BEARING EDGER	1
19	DG.1454	NUT, 7/16-20 LEFT HAND THREAD JAM	1
20	DG.1456	PIN, DOWEL 5/32 X 3/8 EDGER	3

#17 Includes : 1 x DG.1446, 1 x DG.1472, 6 x NB13.109 & 6 x NB25102  
Older Versions of #17 included : 1 x DG.1446 with 1x DG.1488 glued onto it.

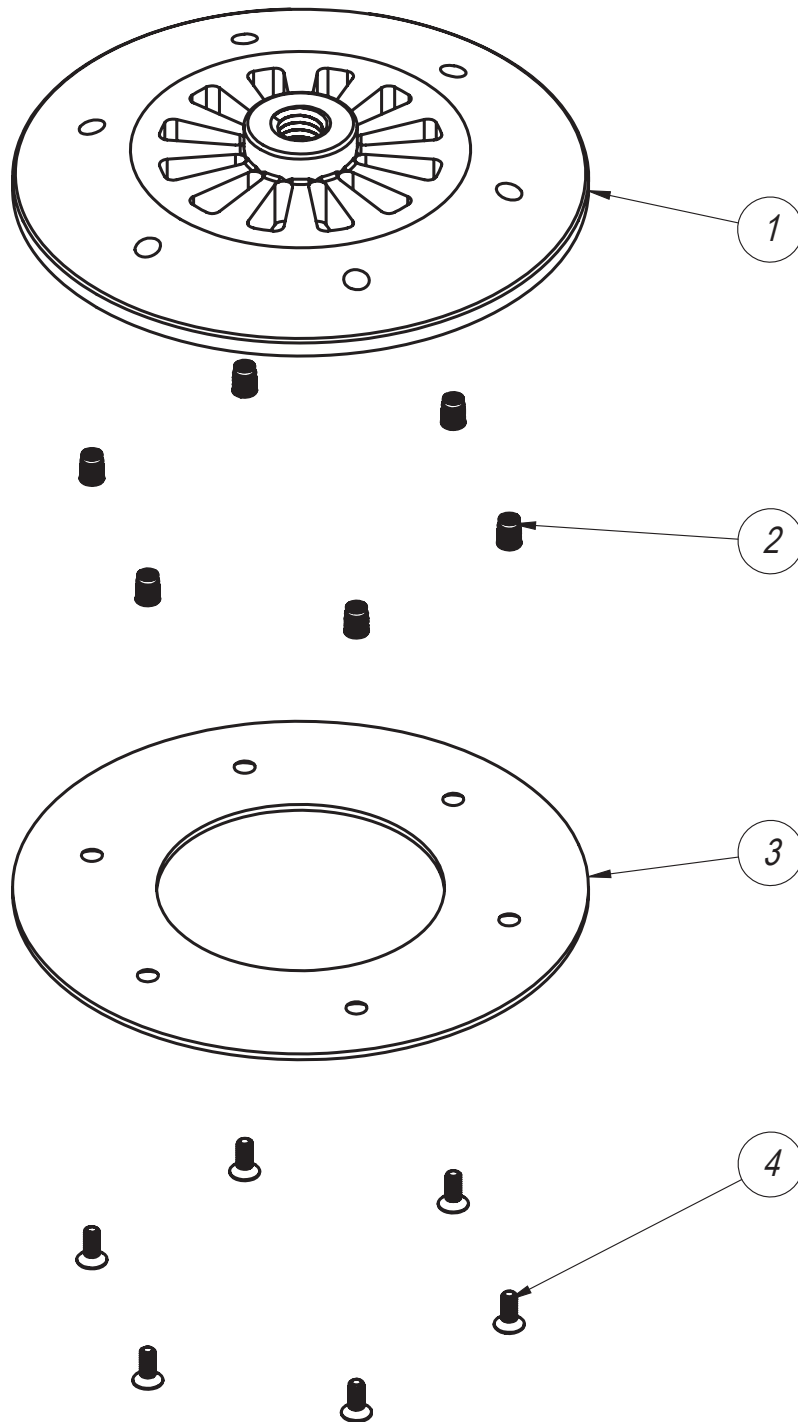

**EDGE PRO 180**

**VELCRO DISK  
ASSEMBLY**

SCALE: 1:2 | WEIGHT: 0.46 | SHEET 1 OF 1

## VELCRO DISC

Item No.	Part No.	Description	Qty
1	DG.1446	DISC, DRIVE EDGER (NO VELCRO)	1
2	NB.25.102	INSERT, THREADED M4-0.7 X 10 FLAT HEAD SOCKET ZINC	6
3	DG.1472	PLATE, SCREW ON VELCRO	1
4	NB.13.109	SCREW, M4-0.7 X 10 FLAT HEAD SOCKET ZINC	6

Older Versions included : 1 x DG.1446 with 1x DG.1488 glued onto it.

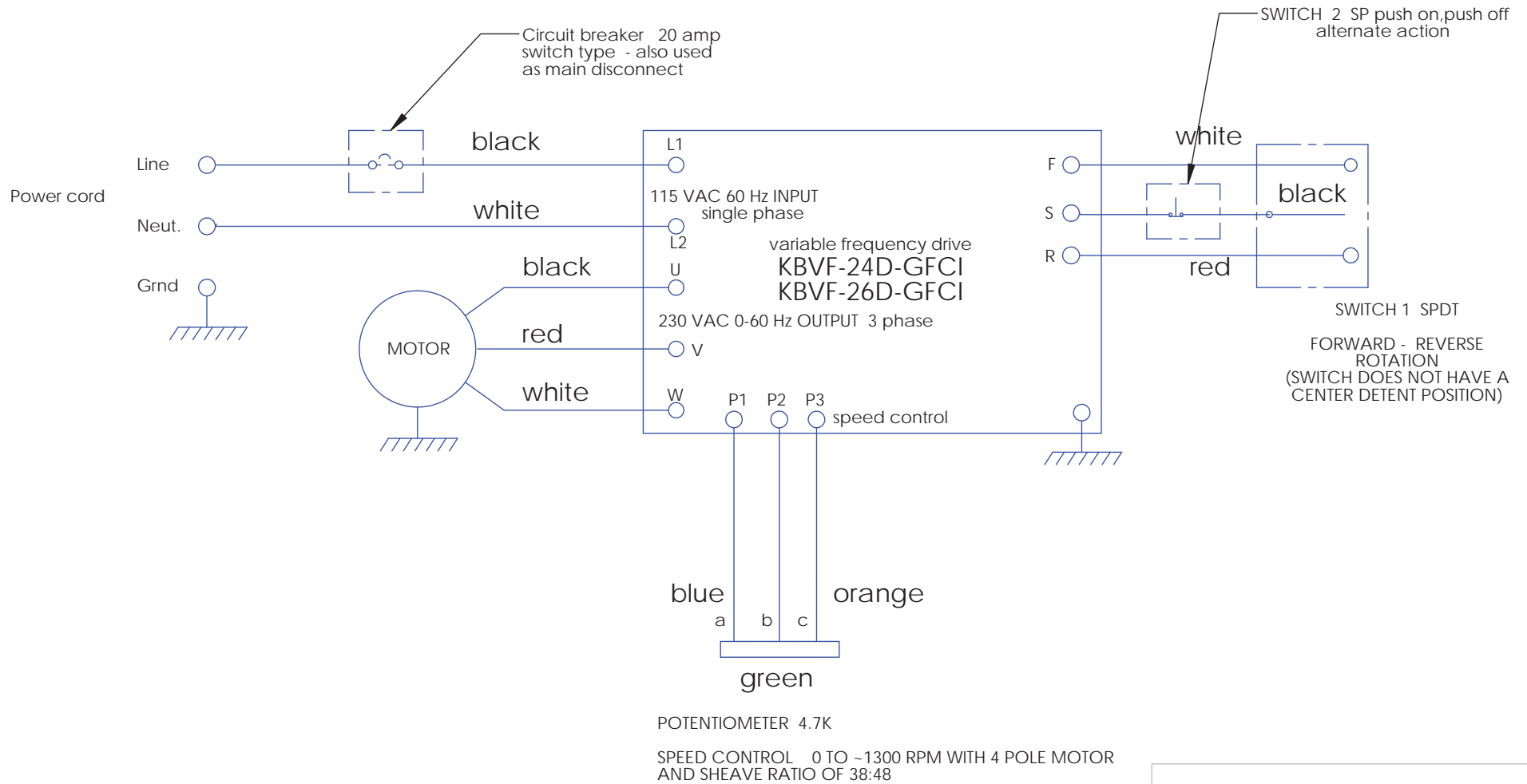

POTENTIOMETER 4.7K

SPEED CONTROL 0 TO ~1300 RPM WITH 4 POLE MOTOR AND SHEAVE RATIO OF 38:48

**SASE COMPANY Inc.**

**EDGER**

**CONTROLLER WIRING**

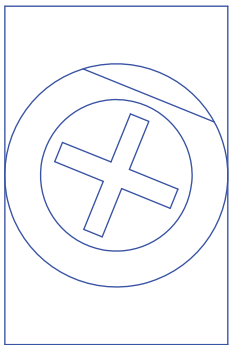

**CL**

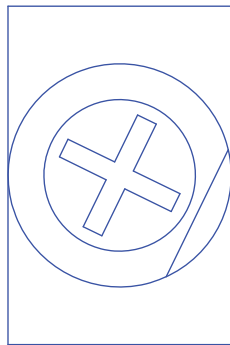

**MAX**

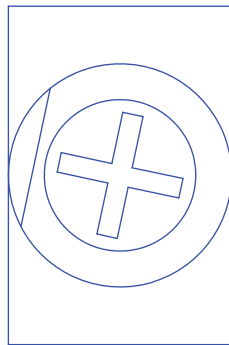

**MIN**

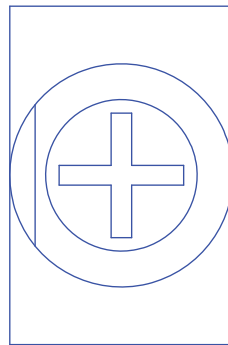

**DEC/B**

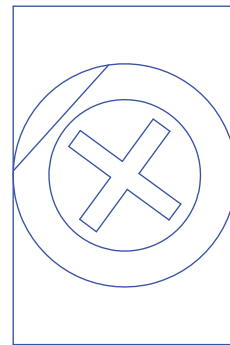

**ACC**

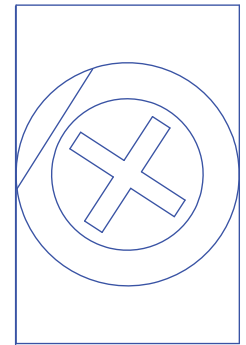

**COMP**

**SASE COMPANY Inc.**

**EDGER**

**CONTROLLER SETTINGS**

5



4

3

2

1

ITEM	QUANT	DISCRIPTION
WIRE	37 INCHES	6 cond. 22AWG ALPHA WIRE 1176C SL005 OR EQUIV.
wire	6 inches	22awg stranded PVC 300v UL1007/1569
Switch 1	1	115 vac SPDT on-none-on switch Allied 676-0033 Cannon CR101J12S215QF
Switch 2	1	SP PB PUSH ON - PUSH OFF ALTERNATE ACTION
POTENTIOMETER	1	4.7k Linear SPECIAL CONFIG. Allied 970-0370, Vishay Dale P16 NP 4K7 20%, linear
connector type 1	3	Quick connect, female, insulated, crimp, 0.197" blade width, #22 AWG
Connector type 2	5	Quick connect, female, insulated, crimp, 0.25" blade width #22 AWG
Connector type 3	5 *	Insulated, butt crimp, #22 AWG * or alternatively solder and heat shrink tube *
Connector type 4	3	Insulated, crimp, end to end plug type, male, #22AWG, quick connect
Connector type 5	3	Insulated, crimp, end to end plug type, female, #22AWG, quick connect
Sub harnesses	1	These wire with female plug harnesses are supplied as part of the motor controller
Misc.	as req'd	Solder, 60/40 rosin core,
Heat shrnk tube	as req'd	1/8" dia (before shrink) heat shrink tube to cover solder connections
Push button boot	1	Sil. rubber Ni pltd brass hex Allied 760-0203, APM Hexseal N3030 2508 <b>RED</b>
Push button boot	1	Sil. rubber Ni pltd brass hex Allied 760-0201, APM Hexseal N3030 2605 <b>GREEN</b>

COLORS IN ALPHA WIRE  
6 COND. 22AWG CABLE:

BLACK  
RED  
WHITE  
GREEN  
ORANGE  
BLUE

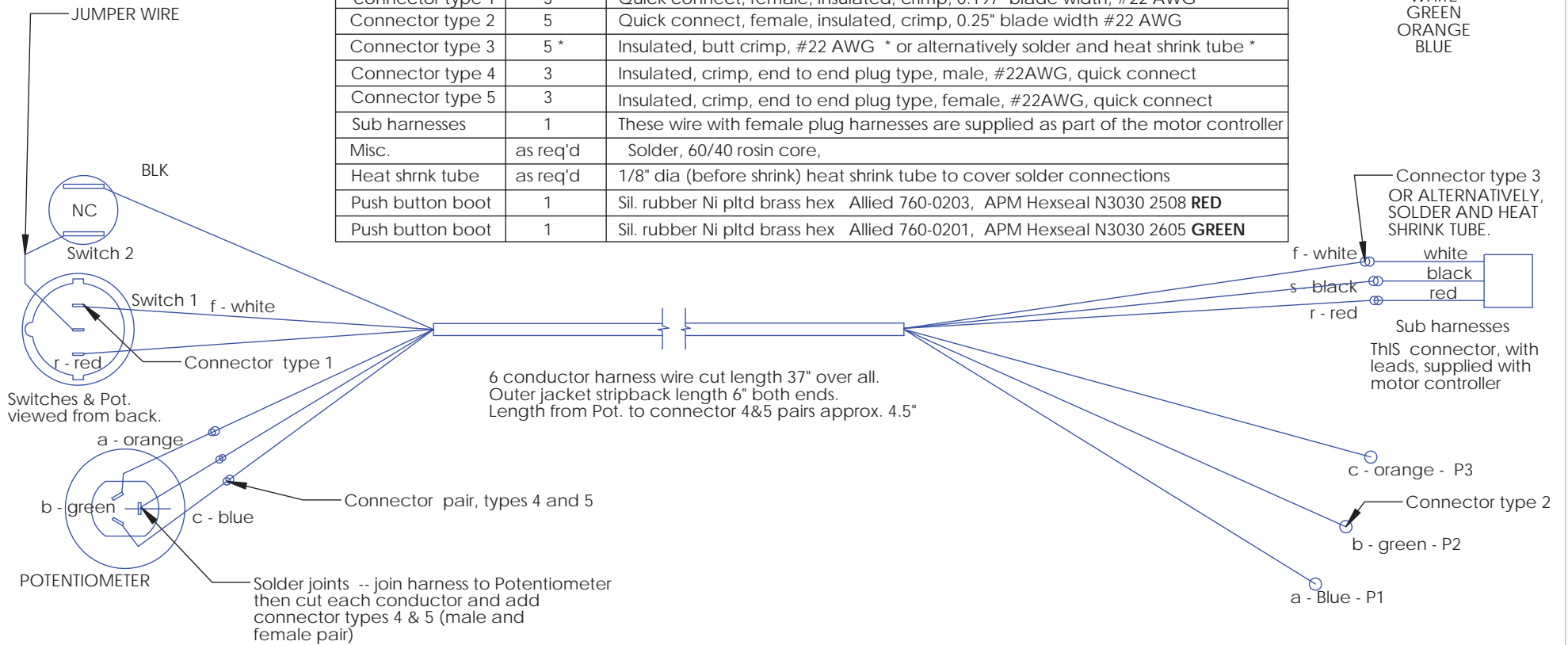

**SASE COMPANY Inc.**

**EDGER**

**WIRING HARNESS**



## MANUFACTURER'S WARRANTY POLICY

### Included in this warranty are the following pieces of equipment:

Planetary Diamond Grinders: PDG 8000, PDG 6000, PDG 5000, Edge Pro 180

Dust Extractors: Bull 1250, Bull 300, Bull 45

Scarifiers: SC12E, SC10E, SC8E

### Our Commitment to our customer:

SASE Company ("SASE") equipment is warranted to be free of defects in workmanship and materials for a period of one (1) year from original date of purchase. In the event that you should have a claim SASE shall repair, replace or remedy the defective parts resulting from the faulty design, materials or workmanship. Note: This warranty is only valid for equipment either sold by SASE or by an authorized wholesaler or distributor.

### Limitations:

- Warranty does not apply to cosmetic damage, damage due to lightning, electrical surges, fire, flood, or other acts of God, accident, misuse, abuse, repair or alteration by other than factory service (unless service center was approved in writing by SASE), negligence, or improper or neglected maintenance as recommended by SASE.
- Common wear parts, such as belts, bearings, seals, filters, dust skirts, wheels, etc., are exempt from warranty.
- SASE is not responsible for loss of income or down time as a result faulty design, materials or workmanship.
- Warranty coverage is valid once a warranty registration card is filled out and returned to SASE.
- A \$100 labor charge may be assessed on the items returned for warranty repair in which no fault is found. Freight charges and associated fees will then become the responsibility of the customer in such an instance.
- Damages which are caused during transportation are not covered under warranty. Such damage claims should be filed with the freight carrier.

### Claims:

In the unlikely event that you should experience a defect please contact your SASE representative or a SASE service technician by calling 1.800.522.2606. Please have all pertinent information readily available such as, invoice with date of purchase, model and serial number, and an explanation of the issue. SASE will respond immediately with a corrective action.

Freight responsibility for approved warranty claims:

If the piece of equipment was purchased within 90 days of warranty claim, SASE will arrange for ground freight and will assume all ground freight charges to send the customer the parts required or to send the equipment to an authorized SASE repair center. This includes inbound and outbound ground freight and all fees (duties, fuel surcharges) associated with the shipment.

If the piece of equipment was purchased beyond 90 days and prior to one (1) year of warranty claim, SASE will cover 50% of all ground freight charges, including inbound and outbound freight and all fees (duties, fuel surcharges) associated with the shipment.



## PRODUCT & WARRANTY REGISTRATION

WARRANTY IS VOID IF NOT RETURNED AND REGISTERED WITH SASE WITHIN 30 DAYS OF PURCHASE

COMPANY \_\_\_\_\_

NAME AND TITLE \_\_\_\_\_

STREET ADDRESS \_\_\_\_\_

CITY \_\_\_\_\_ STATE \_\_\_\_\_ ZIP \_\_\_\_\_ COUNTRY \_\_\_\_\_

PHONE \_\_\_\_\_ EMAIL \_\_\_\_\_

DATE OF PURCHASE \_\_\_\_\_ SERIAL NUMBER \_\_\_\_\_

INVOICE NUMBER OF PURCHASE \_\_\_\_\_

PDG 8000  PDG 6000  PDG 5000  EDGE PRO 180  SC8E

SC10E  SC12E  BULL 1250  BULL 300  BULL 45

PLEASE FILL OUT IN FULL AND SUBMIT TO: SASE COMPANY 2475 STOCK CREEK BLVD  
ROCKFORD TN, 37853 FAX: 865.745.4110 EMAIL: JohnA@SASECompany.com

QUESTIONS? CALL 800.522.2606